

PROTECTION PRODUCTS - RailClamp®

Description

A RailClamp® is a low capacitance TVS array designed to protect high speed data interfaces. This series has been specifically designed to protect sensitive components which are connected to data and transmission lines from overvoltage caused by **ESD** (electrostatic discharge), **CDE** (Cable Discharge Events), and **Lightning**.

The unique design incorporates surge rated, low capacitance steering diodes and a TVS diode in a single package. During transient conditions, the steering diodes direct the transient current to ground. The internal TVS diode clamps the transient voltage to a safe level. The low capacitance array configuration allows the user to protect up to four high-speed data lines.

The RClamp™3304N and RClamp™2504N are constructed using Semtech's proprietary EPD process technology. The EPD process provides low stand-off voltages with significant reductions in leakage current and capacitance over silicon-avalanche diode processes. They feature a true operating voltage of 2.5 volts and 3.3 volts for superior protection.

These devices are in a 10-pin, RoHS/WEEE compliant, SLP2626P10 package. It measures 2.6 x 2.6 x 0.60mm. The leads are spaced at a pitch of 0.5mm and are finished with lead-free NiPdAu. The high surge capability ($I_{pp}=25A$, $t_p=8/20\mu s$) means it can be used in high threat environments in applications such as Gigabit Ethernet, telecommunication lines, and digital video.

Circuit Diagram

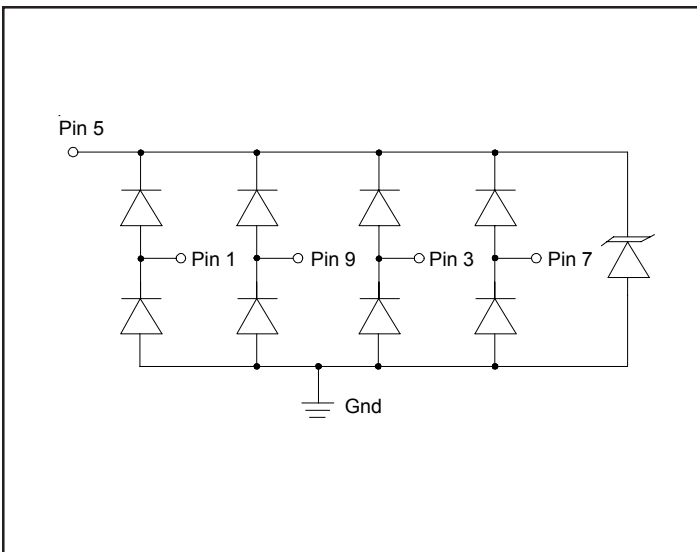

Features

- ◆ Transient protection for high-speed data lines to **IEC 61000-4-2 (ESD) 15kV (air), 8kV (contact)**
IEC 61000-4-4 (EFT) 40A (5/50ns)
IEC 61000-4-5 (Lightning) 25A (8/20μs)
- ◆ Array of surge rated diodes with internal TVS Diode
- ◆ Small package saves board space
- ◆ Protects up to four I/O lines
- ◆ Low capacitance (**<5pF**) for high-speed interfaces
- ◆ Low leakage current and clamping voltage
- ◆ Low operating voltage: **2.5V and 3.3V**
- ◆ Solid-state silicon-avalanche technology

Mechanical Characteristics

- ◆ SLP2626P10 10L package
- ◆ RoHS/WEEE Compliant
- ◆ Nominal Dimensions: 2.6 x 2.6 x 0.60 mm
- ◆ Lead Finish: NiPdAu
- ◆ Molding compound flammability rating: UL 94V-0
- ◆ Marking : Marking Code + Date Code
- ◆ Packaging : Tape and Reel

Applications

- ◆ USB 2.0
- ◆ 10/100/1000 Ethernet
- ◆ Digital Visual Interface (DVI)
- ◆ T1/E1 Secondary Protection
- ◆ T3/E3 Secondary Protection
- ◆ Analog Video

Package Configuration

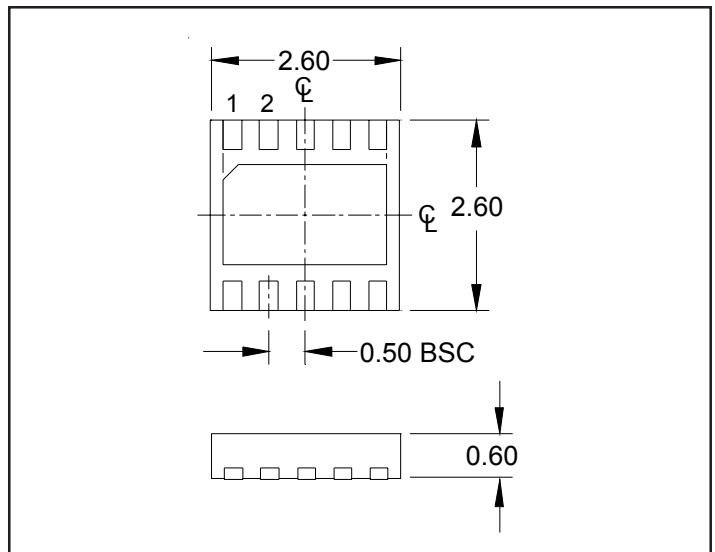

PROTECTION PRODUCTS

Absolute Maximum Rating

Rating	Symbol	Value	Units
Peak Pulse Power (tp = 8/20μs)	P_{pk}	450	Watts
Peak Pulse Current (tp = 8/20μs)	I_{pp}	25	A
ESD per IEC 61000-4-2 (Air) ESD per IEC 61000-4-2 (Contact)	V_{ESD}	25 15	kV
Operating Temperature	T_J	-55 to +125	°C
Storage Temperature	T_{STG}	-55 to +150	°C

Electrical Characteristics (T=25°C)

RClamp2504N						
Parameter	Symbol	Conditions	Minimum	Typical	Maximum	Units
Reverse Stand-Off Voltage	V_{RWM}				2.5	V
Punch-Through Voltage	V_{PT}	$I_{PT} = 2\mu A$	2.7			V
Snap-Back Voltage	V_{SB}	$I_{SB} = 50mA$	2.0			V
Reverse Leakage Current	I_R	$V_{RWM} = 2.5V, T=25^\circ C$			0.5	μA
Clamping Voltage	V_C	$I_{pp} = 1A, t_p = 8/20\mu s$			4.5	V
Clamping Voltage	V_C	$I_{pp} = 10A, t_p = 8/20\mu s$			7.5	V
Clamping Voltage	V_C	$I_{pp} = 25A, t_p = 8/20\mu s$			15	V
Junction Capacitance	C_j	Between I/O pins and Ground $V_R = 0V, f = 1MHz$		3.8	5	pF
		Between I/O pins $V_R = 0V, f = 1MHz$		2.0		pF

Note 1: I/O pins are pin 1, 3, 7, and 9

PROTECTION PRODUCTS

RClamp3304N						
Parameter	Symbol	Conditions	Minimum	Typical	Maximum	Units
Reverse Stand-Off Voltage	V_{RWM}				3.3	V
Punch-Through Voltage	V_{PT}	$I_{PT} = 5\mu A$	3.5			V
Snap-Back Voltage	V_{SB}	$I_{SB} = 50mA$	2.8			V
Reverse Leakage Current	I_R	$V_{RWM} = 3.3V, T=25^\circ C$			5	μA
Clamping Voltage	V_C	$I_{PP} = 1A, t_p = 8/20\mu s$			5.5	V
Clamping Voltage	V_C	$I_{PP} = 10A, t_p = 8/20\mu s$			10.5	V
Clamping Voltage	V_C	$I_{PP} = 25A, t_p = 8/20\mu s$			18	V
Junction Capacitance	C_j	Between I/O pins and Ground $V_R = 0V, f = 1MHz$		3.8	5	pF
		Between I/O pins $V_R = 0V, f = 1MHz$		2.0		pF

PROTECTION PRODUCTS

Typical Characteristics

Non-Repetitive Peak Pulse Power vs. Pulse Time

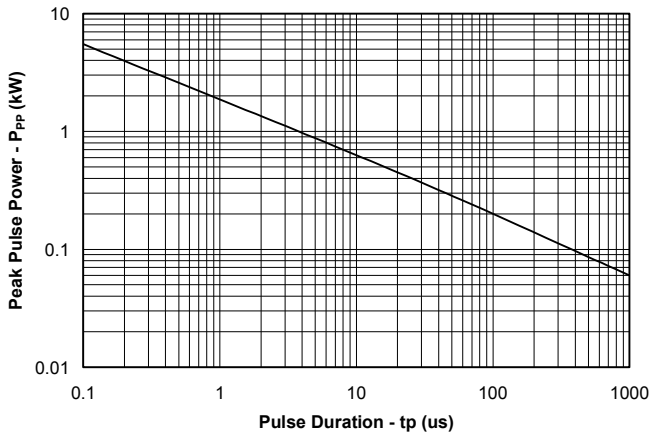

Power Derating Curve

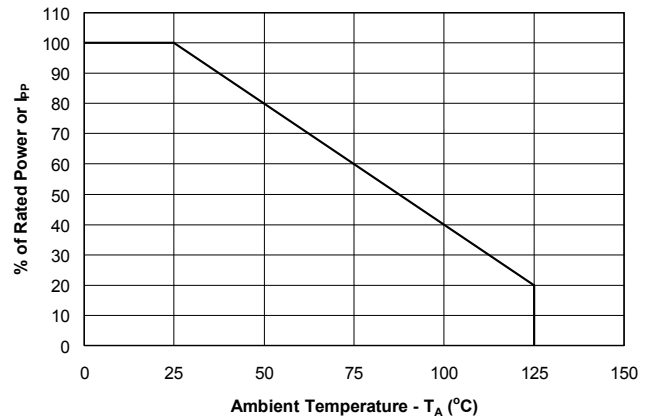

Pulse Waveform

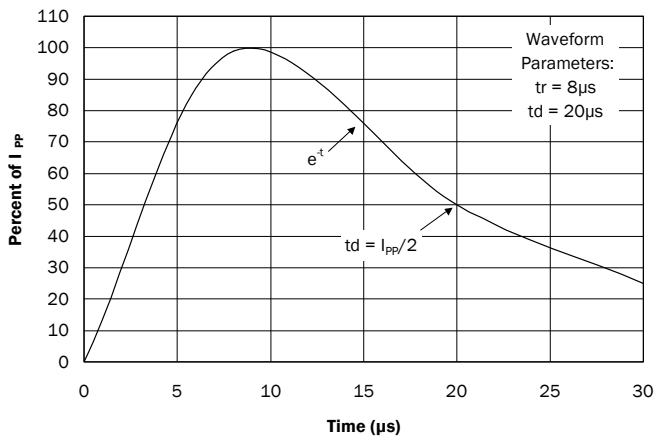

Normalized Junction Capacitance vs. Reverse Voltage

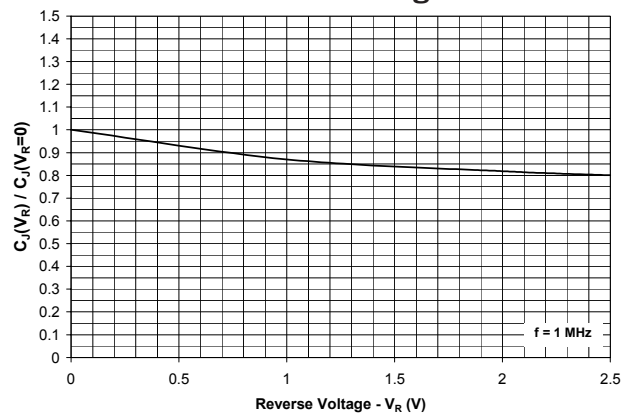

Clamping Voltage vs. Peak Pulse Current I/O to GND

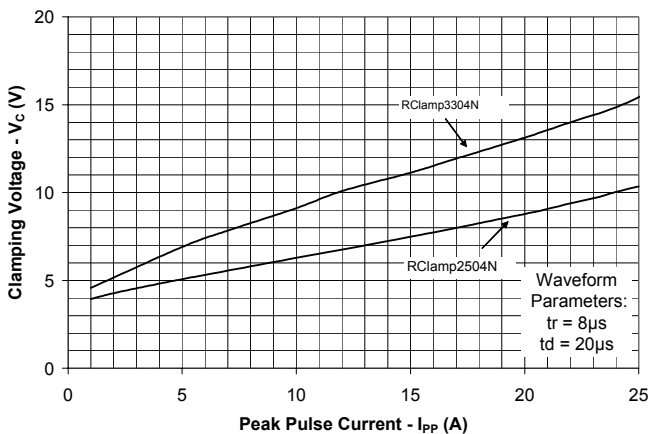

Clamping Voltage vs. Peak Pulse Current I/O to I/O

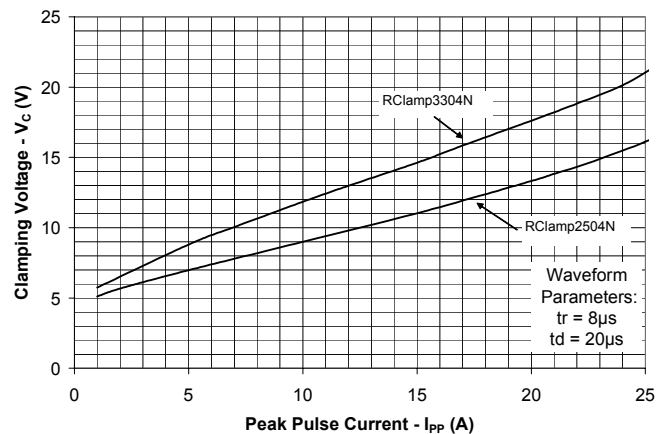

PROTECTION PRODUCTS

Typical Characteristics

Insertion Loss S21 (I/O to Ground)

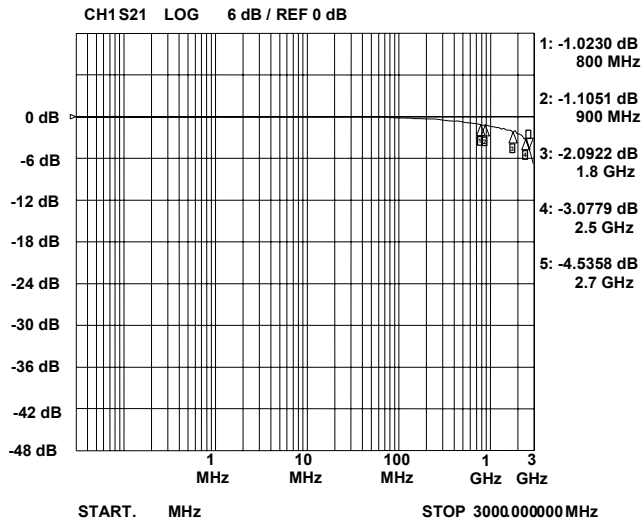

**ESD Clamping
(8kV Contact per IEC 61000-4-2)**

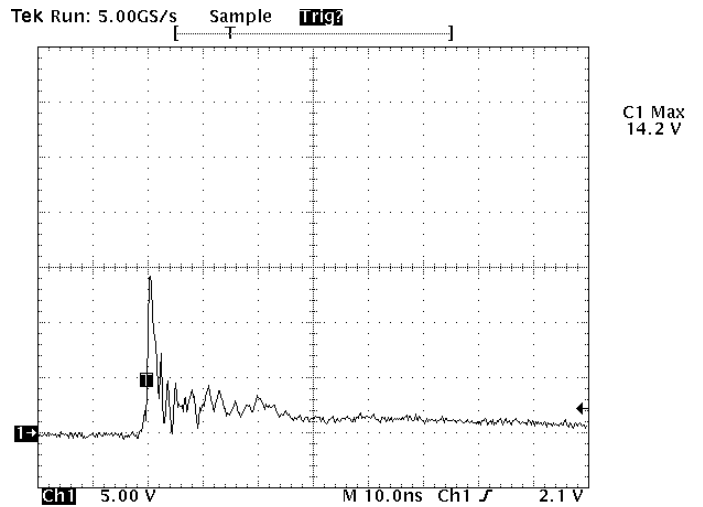

Note: Data is taken with a 10x attenuator

PROTECTION PRODUCTS

Applications Information

Device Connection Options for Protection of Four High-Speed Data Lines

These devices are designed to protect low voltage data lines operating at 2.5 volts or 3.3 volts. When the voltage on the protected line exceeds the reference voltage the steering diodes are forward biased, conducting the transient current away from the sensitive circuitry.

Data lines are connected at pins 1, 3, 7 and 9. The center pin should be connected directly to a ground plane. The path length is kept as short as possible to minimize parasitic inductance. Pins 2, 4, 6, 8, and 10 are not connected.

Note that pin 5 is connected internally to the cathode of the low voltage TVS. It is not recommended that these pins be directly connected to a DC source greater than the snap-back voltage (V_{SB}) as the device can latch on as described below.

EPD TVS Characteristics

These devices are constructed using Semtech's proprietary EPD technology. By utilizing the EPD technology, the RClamp2504N and RClamp3304N can effectively operate at 2.5V and 3.3V respectively while maintaining excellent electrical characteristics.

The EPD TVS employs a complex npn structure in contrast to the pn structure normally found in traditional silicon-avalanche TVS diodes. Since the EPD TVS devices use a 4-layer structure, they exhibit a slightly different IV characteristic curve when compared to conventional devices. During normal operation, the device represents a high-impedance to the circuit up to the device working voltage (V_{RWM}). During an ESD event, the device will begin to conduct and will enter a low impedance state when the punch through voltage (V_{PT}) is exceeded. Unlike a conventional device, the low voltage TVS will exhibit a slight negative resistance characteristic as it conducts current. This characteristic aids in lowering the clamping voltage of the device, but must be considered in applications where DC voltages are present.

When the TVS is conducting current, it will exhibit a slight "snap-back" or negative resistance characteristics due to its structure. This point is

Circuit Diagram

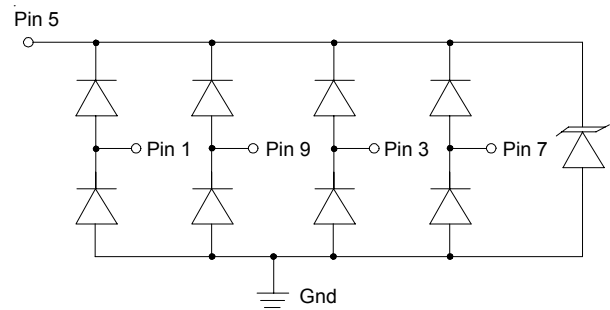
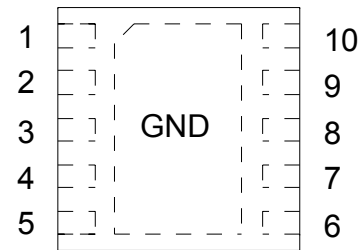
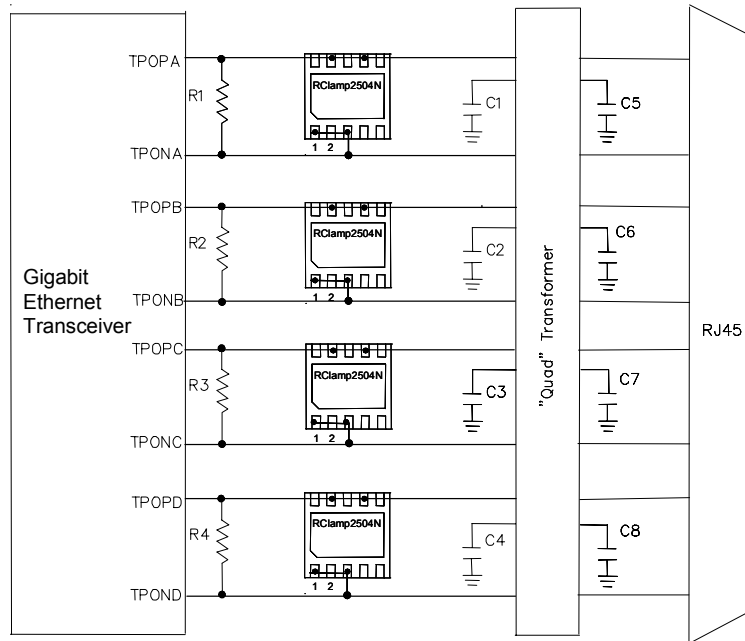

Figure 1. Pin Configuration (Top Side View)



Pin	Identification
1, 3, 7, 9	Input/Output Lines
2, 4, 6, 8, 10	No Connect
5	No Connect (Do not connect this pin to a DC supply)
Center Tab	Ground

defined on the curve by the snap-back voltage (V_{SB}) and snap-back current (I_{SB}). To return to a non-conducting state, the current through the device must fall below the I_{SB} (approximately $<50\text{mA}$) and the voltage must fall below the V_{SB} (normally 2.8 volts for a 3.3V device). If a 3.3V TVS is connected to 3.3V DC source, it will never fall below the snap-back voltage of 2.8V and will therefore stay in a conducting state.



**Schematic Diagram for Gigabit Ethernet Telcordia GR-1089 Intra-Building Protection
(PHY Operating Temp $\leq 90^{\circ}\text{C}$)**

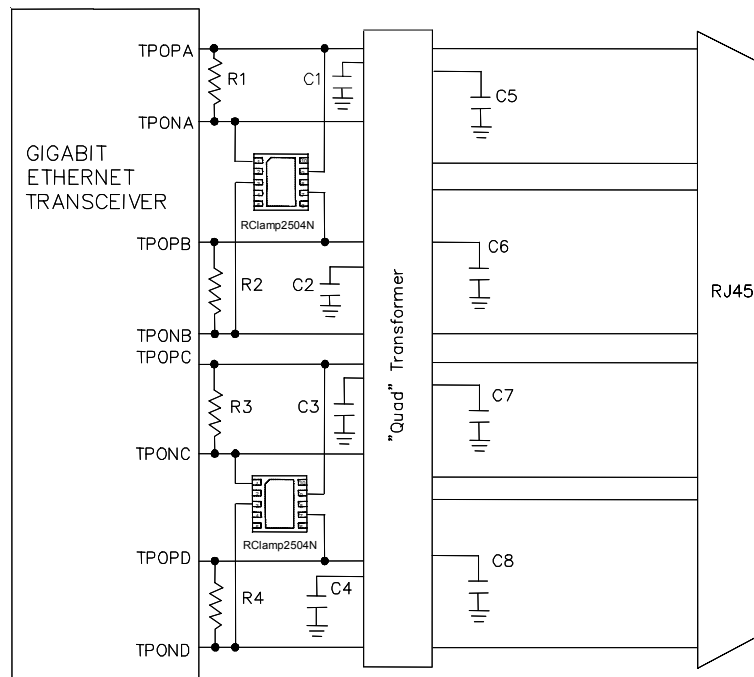

Schematic Diagram for Gigabit Ethernet ESD Protection

PROTECTION PRODUCTS

Applications Information - Spice Model

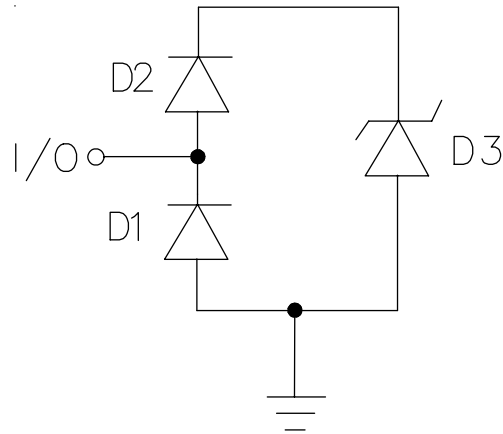

RClamp2504N Spice Model

RClamp2504N Spice Parameters				
Parameter	Unit	D1 (LCRD)	D2 (LCRD)	D3 (TVS)
IS	Amp	1E-20	1E-20	1.66E-13
BV	Volt	100	100	2.89
VJ	Volt	0.63	0.59	0.53
RS	Ohm	0.138	0.241	0.06
IBV	Amp	1E-3	1E-3	1E-3
CJO	Farad	1.5E-12	1.5E-12	288E-12
TT	sec	2.541E-9	2.541E-9	2.541E-9
M	--	0.01	0.01	0.17
N	--	1.1	1.1	1.1
EG	eV	1.11	1.11	1.11

PROTECTION PRODUCTS

Applications Information - Spice Model

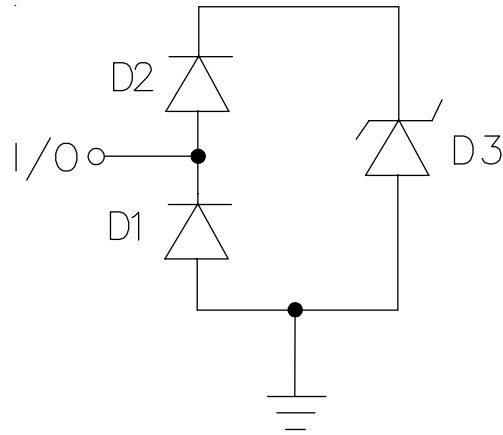

RClamp3304N Spice Model

RClamp3304N Spice Parameters				
Parameter	Unit	D1 (LCRD)	D2 (LCRD)	D3 (TVS)
IS	Amp	1E-20	1E-20	1.66E-13
BV	Volt	100	100	3.55
VJ	Volt	0.62	0.59	0.6
RS	Ohm	0.138	0.241	0.182
IBV	Amp	1E-3	1E-3	1E-3
CJO	Farad	1.5E-12	1.5E-12	253E-12
TT	sec	2.541E-9	2.541E-9	2.541E-9
M	--	0.01	0.01	0.205
N	--	1.1	1.1	1.1
EG	eV	1.11	1.11	1.11

PROTECTION PRODUCTS

Outline Drawing - SLP2626P10

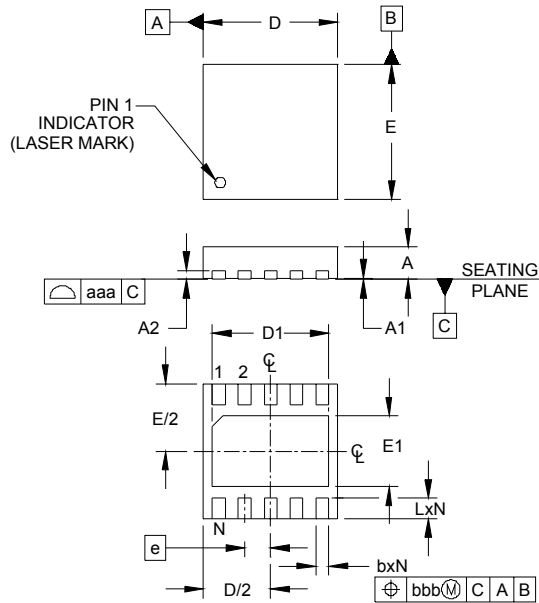

DIM	DIMENSIONS					
	INCHES			MILLIMETERS		
	MIN	NOM	MAX	MIN	NOM	MAX
A	.020	.024	.026	0.50	0.60	0.65
A1	.000	.001	.002	0.00	0.03	0.05
A2	(.007)			(0.17)		
b	.007	.010	.012	0.20	0.25	0.30
D	.098	.102	.106	2.50	2.60	2.70
D1	.079	.085	.089	2.00	2.15	2.25
E	.098	.102	.106	2.50	2.60	2.70
E1	.044	.050	.054	1.11	1.26	1.36
e	.020 BSC			0.50 BSC		
L	.011	.014	.016	0.30	0.35	0.40
N	10			10		
aaa	.003			0.08		
bbb	.004			0.10		

NOTES:

1. CONTROLLING DIMENSIONS ARE IN MILLIMETERS (ANGLES IN DEGREES).
2. COPLANARITY APPLIES TO THE EXPOSED PAD AS WELL AS THE TERMINALS.

Land Pattern - SLP2626P10

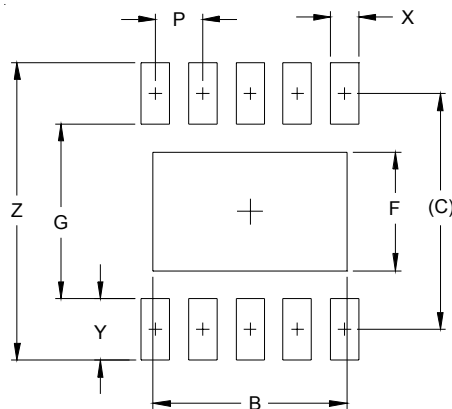

DIM	DIMENSIONS	
	INCHES	MILLIMETERS
B	.081	2.05
C	.100	2.50
F	.050	1.26
G	.073	1.85
P	.020	0.50
X	.012	0.30
Y	.025	0.65
Z	.124	3.15

NOTES:

1. THIS LAND PATTERN IS FOR REFERENCE PURPOSES ONLY. CONSULT YOUR MANUFACTURING GROUP TO ENSURE YOUR COMPANY'S MANUFACTURING GUIDELINES ARE MET.

PROTECTION PRODUCTS

Marking

2504N
YYWW



RClamp2504N

3304N
YYWW



RClamp3304N

YYWW = Date Code

Ordering Information

Part Number	Working Voltage	Qty per Reel	Reel Size
RClamp2504N.TCT	2.5 Volts	3,000	7 Inch
RClamp3304N.TCT	3.3 Volts	3,000	7 Inch

RailClamp and RClamp are marks of Semtech Corporation

Tape and Reel Specification

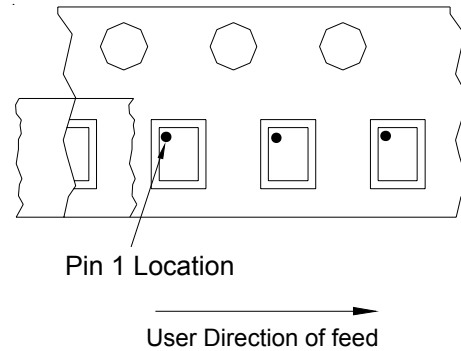
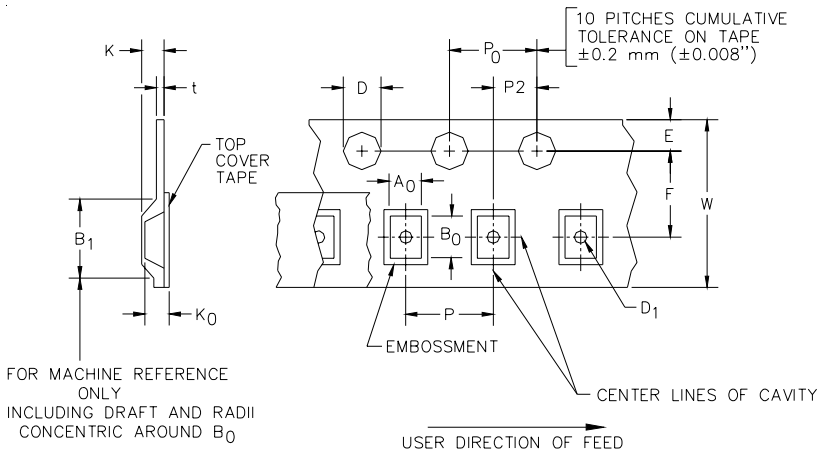

Device Orientation in Tape

A0	B0	K0
2.77 +/-0.05 mm	2.77 +/-0.05 mm	0.80 +/-0.05 mm

Tape Width	B, (Max)	D	D1	E	F	K (MAX)	P	P0	P2	T(MAX)	W
8 mm	4.2 mm (.165)	1.5 + 0.1 mm - 0.0 mm	1.0 mm ±0.05	1.750±.10 mm	3.5±0.05 mm	2.4 mm	4.0±0.1 mm	4.0±0.1 mm	2.0±0.05 mm	0.4 mm	8.0 mm + 0.3 mm - 0.1 mm

Contact Information

Semtech Corporation
 Protection Products Division
 200 Flynn Rd., Camarillo, CA 93012
 Phone: (805)498-2111 FAX (805)498-3804